



## **INSTALLATION & INSTRUCTION MANUAL**

### **CLEARADON<sup>®</sup> SERIES 3311 SHALLOWTRAY<sup>®</sup> AERATION SYSTEM**

## TABLE OF CONTENTS

<b>SAFETY FIRST!</b> .....	1
<b>INSTALLATION PROCEDURE</b> .....	2
Step 1 – Determine Well Pump Flow Rate.....	2
Step 2 – Prepare the Site .....	3
Step 3 – Unpack the Clearadon® Series 3311 .....	3
Step 4 – Connect the Pressure Tank .....	3
Step 5 – Attach Top Hose .....	5
Step 6 – Attach Bottom Hose .....	5
Step 7 – Connect Solenoids .....	5
Step 8 – Shut Down Power and Water Supply.....	5
Step 9 – Plumb Unit .....	5
Step 10 – Connect Electrical Power Supply .....	5
Step 11 – Install Vent Line and Vent Fan .....	7
<b>START UP THE CLEARADON® SERIES 3311</b> .....	9
Step 1 – Bypass System.....	9
Step 2 – Turn off Pump .....	9
Step 3 – Power Up .....	9
Step 4 – Bring Clearadon® Series 3311 On-line .....	9
Step 5 – Turn Clearadon® Series 3311 On .....	9
Step 6 – Prime the Pump .....	9
Step 7 – Start the Pump.....	9
<b>INSTALLATION CHECK LIST</b> .....	10
Step 1 – By-Pass.....	10
Step 2 – Uncouple the Vent Line and Inspect Float.....	10
Step 3 – Check Level Again .....	10
Step 4 – Disinfect .....	10
Step 5 – Seal .....	10
Step 6 – Verify Operation .....	10
Step 7 – One Month Later .....	10
<b>OPERATING SEQUENCE FOR THE CLEARADON® SERIES 3311</b> .....	11

<b>MAINTENANCE</b> .....	12
Water System Disinfection .....	12
Six Month Check .....	12
Step 1 – Test Water Quality .....	12
Step 2 – Check the Following:.....	12
Step 3 – Disinfect .....	13
Annual Check .....	13
Step 1 – Same Again .....	13
Step 2 – Replace Air Filter .....	13
Step 3 – Switch Solenoid Coil Positions .....	13
Five Year Check.....	13
Step 1 – Perform the Six Month and Annual Checks .....	13
Step 2 – Replace the Solenoid Valves .....	13
Step 3 – Replace All Hoses .....	13
<b>TROUBLESHOOTING GUIDE</b> .....	14
Poor Contamination Removal.....	14
Step 1 – System Level? .....	14
Step 2 – Check Vent Length .....	14
Step 3 – Check Vent Cap .....	14
Step 4 – Check Vent Line .....	14
Step 5 – Check Blower Air Filter.....	14
Step 6 – Check Auxiliary Fan .....	14
Step 7 – Check Outlet Weir.....	15
Step 8 – Check Aeration Tray.....	15
Step 9 – Check By-Pass Valve.....	15
Step 10 – Check Test Results .....	15
Problem: Air in Water .....	15
Step 1 – Check Well Flow Rate .....	15
Step 2 – Check Water Feed.....	15
Problem: Pump Will Not Shut Off.....	16
Step 1 – Check Tile Pressure .....	16
Problem: Low Water Flow .....	16

Step 1 – Determine Well Flow Rate .....	16
Step 2 – Check for Obstruction in Suction Side of Pump .....	16
Step 3 – Check for Obstruction on Discharge Side of Pump .....	16
Problem: Pump Malfunction after a Power Failure .....	16
Step 1 – Check Pump .....	17
Problem: Pump Starts but No Water Flow .....	17
Step 1 – Examine Check Valve .....	17
Problem: Pump Quits, House Requires Water.....	17
Step 1 – Check Flow Rate.....	17
Step 2 – Check Plumbing .....	17
Step 3 – Check Pressure Switch .....	17
Step 4 – Check Circuit Breaker.....	17
<b>ELECTRICAL PROBLEMS</b> .....	<b>18</b>
Problem: System Will Not Start .....	18
Step 1 – Check Pump .....	18
Step 2 – Check Aeration Tank Fuse.....	18
Step 3 – Power Failure or Circuit Breaker Reset .....	18
Problem: Solenoids Do Not Operate .....	18
Problem: Blower Malfunction .....	18
Step 1 – Check Relay Contacts.....	18
Problem: Blower Runs Continuously .....	18
Step 1 – Check Float Switch .....	18
Step 2 – Check Relay .....	19
Step 3 – Check Timer .....	19
<b>PACKING LIST</b> .....	<b>20</b>
<b>INSTALLATION OVERVIEW</b> .....	<b>20</b>

## **SAFETY FIRST!**

This manual has been written to guide the purchaser, designated installer, systems professional, or user through the steps required to safely and effectively install the Clearadon® Series 3311 ShallowTray® aeration system from Spruce Environmental Technologies, Inc.

Please read this entire manual before attempting to install or service the Clearadon® Series 3311. If you are not the person who will install the unit, give these instructions to the person who will actually perform the job.

The installation procedures have been written in sequence. Do not skip any steps or attempt short cuts. Short cuts never are. Please follow the procedures carefully, and check with your local authority regarding necessary permits, permissions, and code requirements before actually beginning the installation procedure. Installation must be performed by trained and licensed personnel. We suggest that the Clearadon® Series 3311 be installed by a factory-trained plumber, contractor, or water treatment system specialist. Installation by anyone other than the above will void the factory equipment warranty. We suggest that you employ a strong helper to assist the installer in lifting and moving the unit to its destination. If you require further information or clarification, please call your local Spruce Environmental technologies Inc.

**SAFETY SHOULD BE YOUR PRIME OBJECTIVE. CAREFULLY FOLLOW ALL THE STEPS IN THIS MANUAL. WORK SLOWLY AND STEADILY IN ORDER TO AVOID INJURY.**

## INSTALLATION PROCEDURE

**SAFETY FIRST! ENSURE THAT THE FOLLOWING STEPS ARE COMPLETED IN SEQUENCE BY A LICENSED PLUMBER, CONTRACTOR AND ELECTRICIAN OR CERTIFIED WATER TREATMENT SYSTEM SPECIALIST. THE INSTALLER SHOULD BE AWARE OF, AND ADHERE TO, ALL PERTINENT LOCAL AND STATE CODES.**

### Step 1 – Determine Well Pump Flow Rate

This step will determine the required flow restrictor. The unit is equipped with the standard 6 GPM outlet flow restrictor. The well pump output must be 7 GPM or greater. If not, the Clearadon® Series 3311 will run dry and possible damage to the pump may result. A lower GPM, or the need for a higher GPM output from the Clearadon® Series 3311, will require the appropriate flow restrictors. You will need the following in order to determine the flow rate:

- A garden hose
- A five-gallon bucket
- A watch with second hand
- A calculator, paper and pencil, or a head for figures

It is important that there are no demands on the well pump during this test. Turn off all faucets, sprinklers, hoses, etc., and inform others that you are about to begin a flow rate test.

1. Connect a garden hose to the house pressure tank drain valve.
2. Open the drain valve and collect the water in the bucket.
3. When the electric pump turns on, close drain valve and let pump fill the pressure tank.
4. Once the tank is full, wait until the pump turns itself off.
5. Empty the water from the bucket.
6. With your watch in hand, open the drain valve and collect all the discharged water in the bucket until the pump turns on. Immediately close the drain valve and begin timing the pump cycle.
7. Keep timing until the pump turns off; note the elapsed time in seconds.
8. Measure the volume of water (gallons) in the bucket.
9. Divide the number of gallons collected in #6 by the number of seconds in #7.

10. Multiply the answer by **60** to convert to minutes. This gives you the system's true pumping capacity. *Note: It may be prudent to complete the above exercise twice and average the results.*

For example:

*Number of gallons collected in #5 = 9 gallons.*

*Number of seconds in #7 = 72 seconds.*

*GPM (gallons collected/seconds in cycle) x 60 seconds*

*GPM = (9/72) x 60*

*GPM = 0.125 x 60*

*GPM = 7.5*

## Step 2 – Prepare the Site

The Clearadon® Series 3311 unit must be vented in order for it to operate. Before beginning work (which includes unpacking the unit), please ensure that the proposed installation site has clear access to the exterior, and that the **equivalent** vent pipe length will not exceed 95 feet. Please refer to **Step 11** to determine the vent pipe length and site suitability.

The Clearadon® Series 3311 must be placed on firm and level footing. A concrete slab is ideal. If the site is unstable, have a building contractor pour a suitably reinforced concrete slab to accept the unit. The Clearadon® Series 3311 weighs approximately 450 pounds when installed and operating. Have a dedicated 115 volt, 20 amp outlet and circuit breaker installed.

## Step 3 – Unpack the Clearadon® Series 3311

Remove the packing materials from the unit and verify the contents against the packing list. See Figure 1 for a detailed parts list. Clear a safe path to the installation site. Utilize a suitable helper to assist you in carrying the unit to its destination.

Use correct lifting protocol to protect your back from unnecessary strain. Place the unit on the prepared installation site and check that it's safe and level.

Remove the lid from the Clearadon® Series 3311 by unhooking its latches and vent coupling. Use a carpenter's level to verify that the holding tank is level in all directions. Replace and secure the tank lid and vent coupling.

## Step 4 – Connect the Pressure Tank

Locate pump and tank (sold separately) next to Clearadon Series 3311. Connect an appropriate bypass (Diverta-Flo piston type or 3 ball-valve setup. Both sold separately) and included solenoids to pump and tank assembly. The tank must be installed in an upright position.

SEE FIGURE 1 (page 5)

## CLEARADON® SERIES 3311 – PLUMBING DIAGRAM

ITEM	QTY	PART NO.	DESCRIPTION
B1	1	79076-3	Nozzle,10.0gpm@15psi,.375,PVC
B2	1	79161-2	Bushing,HEX 3/4"x3/8"Sched80
B3	1	79174-2	Bulkhead,.75,TxT,PVC80
B7	1	79065-1	Elbow,PVC 3/4"90 Insert X MIPT sch.80
B9	1	79094-2	Adapter ,PVC 1" Male insert x MIPT
B10	1	-	Check Valve, Lead Free 1"
B12	1	79065-2	Elbow,PVC 1"90 Insert X MIPT sched.80
B13	1	79174-3	Fitting,Bulkhead 1"TxT EPDM PVC
B14	1	79166	Elbow,Street 90,1.0,TxS,PVC40
B15	6	67069	Hose Clamp 13/16-13/4 1/2"V SS

ITEM	QTY	PART NO.	DESCRIPTION
A1	1	79173	Valve, Bypass, .75"F, TxT LF Brass
A2	3	79094-1	Adapter ,PVC 3/4" Male insert x MIPT
A4	10FT	78028-1	Hose, PVC 3/4" food & beverage
A5	1	79119-1	Nipple, 3/4" CLOSE TBE Sch80
A6	1	79163	Restrictor Flow, Dole 3/4" 6GPM
A7	1	51154	20 Gallon Expansion Tank
A8	2	79107-8	Tee,3/4"x3/4"x3/4" Sharkbite
A9	2	79161-7	Bushing 1.0Mx .75F TxT CPVC
A11	4FT	78028-2	Hose,PVC 1" food/beverage
A12	1	50011	Gauge, Pressure 0-100 PSI
A13	1	79099-21	Nipple, 1/4" NPT Close Sch 80
A14	1	-	Tee, 1/4" FIPT Lead Free Bronze
A15	1	51106	Kit, Pump Goulds 1/2hp 115V
A17	2	98046	Valve,Solenoid 3/4NC DIN Noryl
A18	1	79163	Elbow, 3/4" MNPT x 3/4" Pex LF Poly Alloy
A19	1	79170	Restrictor Flow, Dole 3/4" 7GPM
A20	1	-	Bushing 1.25Mx 1.0F TxT CPVC
A21	1	79106-17	Elbow,1"Pex x 1"Pex 90 LF Brass
A22	1	78037-3	Tubing,Blue 1" Aquapex
A24	1	-	Boiler Drain, 3/4" Lead Free Brass
A25	3x3IN	78037-2	Tubing, Pex 3/4" Dia, Blue
A26	6	79106-11	Crimp Ring 3/4" Hydropex SS
A27	4	T9106-16	Crimp Ring,1" Hydropex SS
A28	3	79106-7	Adapter, 3/4" FNPT x 3/4" Pex LF Brass
A29	2	-	Adapter, 1" MNPT x 1" Pex LF Brass
A30	1	79107-5	Adapter, 3/4" MNPT x 3/4" Pex LF Brass
A31	5x2IN	78037-2	Tubing, Pex 3/4" Dia, Blue

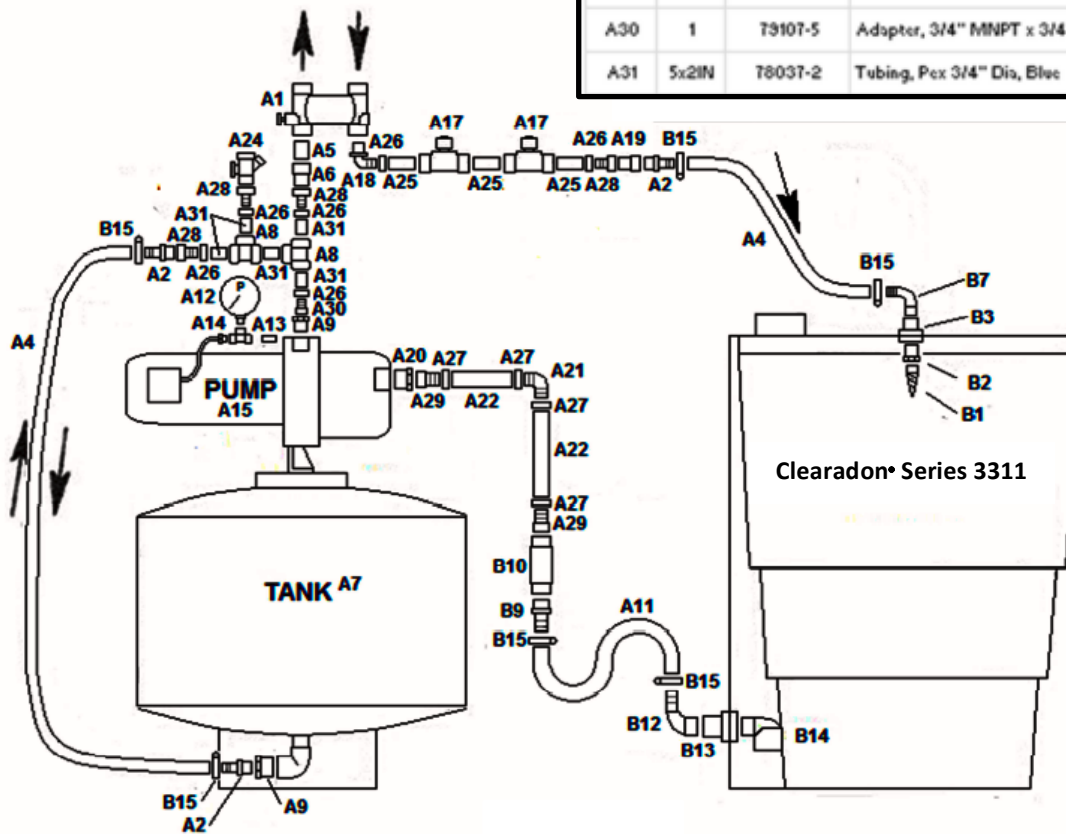

FIGURE 1



#### Step 5 – Attach Top Hose

Attach the hose from the top of the Clearadon® Series 3311 to the **bypass/solenoid assembly**.

#### Step 6 – Attach Bottom Hose

Attach the hose from the bottom of the Clearadon® Series 3311 to the intake of the pump.

#### Step 7 – Connect Solenoids

Plug solenoid lead into each solenoid, secure with screw.

#### Step 8 – Shut Down Power and Water Supply

Shut down the power and water service to the well pump circuit in the following order:

1. Shut off electrical power to the existing well pump.
2. Shut off the circuit breaker or fuse that controls the existing well pump circuit. Check your work with a multi-tester to be sure that the power is off.
3. Shut off the electric water heater and close intake and outlet valves.
4. Shut off the main water supply from existing pressure tank to the house or structure.

**SAFETY FIRST! FAILURE TO COMPLETE THE ABOVE 4 STEPS AND DISCONNECT ALL POWER SUPPLIES TO THE WELL PUMP SYSTEM COULD CAUSE SERIOUS INJURY OR DAMAGE TO PROPERTY.**

#### Step 9 – Plumb Unit

Identify the water line beginning at the building's existing pressure tank. Ensure that the existing well pump has been turned off then drain the water line into a bucket. When water ceases to flow, cut the pipe after the existing pressure tank but before the house shut off valve. Plumb to the **Water In** connection on the **by-pass/solenoid assembly**. (Note: It is good practice to install a water filter or strainer in the water inlet line. This is to protect the solenoids from plugging with sediment). Plumb from the **Water Out** connection to the building's main supply line. Check your work.

#### Step 10 – Connect Electrical Power Supply

**SAFETY FIRST! ELECTRICAL WIRING MUST BE COMPLETED BY A QUALIFIED AND LICENSED TECHNICIAN.** See Figure 2 for an overview of the electrical system.

# CLEARADON® SERIES 3311 – WIRING DIAGRAM

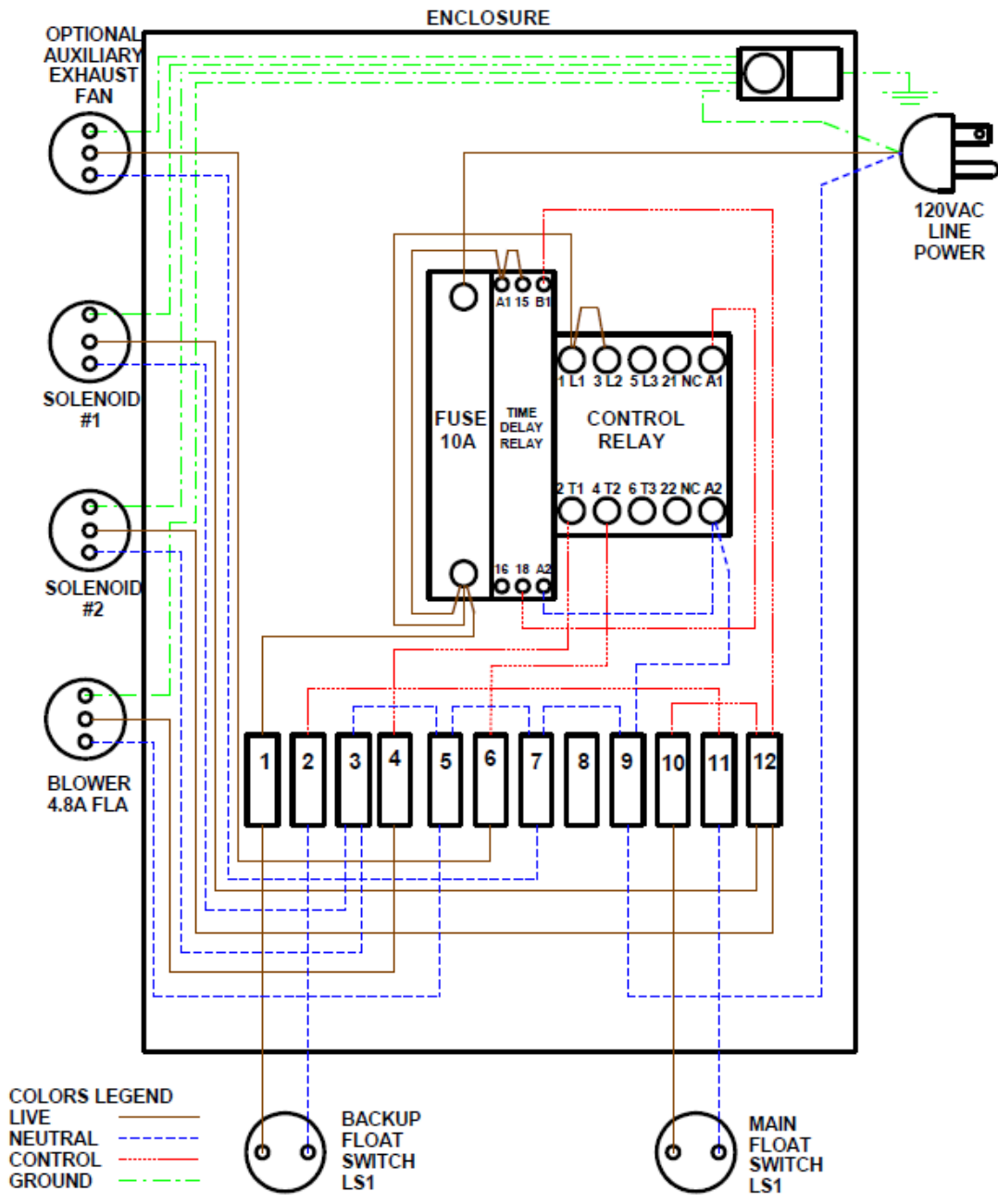

**CAUTION**  
REPLACE ALL FUSES WITH SAME TYPE,  
VOLTAGE & AMP RATING.

CONNECT TO A SEPARATE 15 A CIRCUIT  
BREAKER PER LOCAL AND NATIONAL  
ELECTRICAL CODE

FIGURE 2

## Step 11 – Install Vent Line and Vent Fan

Please refer to Figure 3 before beginning the vent pipe installation.

Begin by installing the 4 inch **flexible coupling** between the vent stack and the vent line. The coupling is required in order to complete cleaning and regular maintenance procedures.

If the unit is being installed in a house under construction, it is preferable if the vent line is routed to the exterior in the same manner as a sewer vent line. However, **do not** hook the vent line into the sewer line.

Vent pipe material should be 4 inch PVC schedule 40 or foam core pipe. Use as short a run as possible and keep elbows to a minimum. The entire run, including elbows, must not exceed the 95 foot maximum. Consult the illustration for a typical installation example. The vent line must slope back slightly toward the Clearadon® Series 3311 unit in order for water to run back to the unit and not collect inside the venting system.

Rough-in a 4 inch PVC vent line and determine the placement of the vent fan. Install the fan in a vertical section of the vent line using two **flexible couplings**. Have your electrician consult the wiring diagram on the inside of the control panel, and connect the fan to the main control box terminals labeled **vent fan** on the Clearadon® Series 3311. Secure the electrical cable in adherence to local codes.

Install a vent cap with a flapper (or 1 /4" mesh screen) at the end of a 90 degree elbow at the vent end.

If the vent line cannot be run to roof level inside the building, then it must be run externally. The pipe must be carefully secured to the exterior of the structure and capped as described above.

Once the vent pipe has been installed and checked, secure all the pipe joints with suitable PVC pipe joint cement.

## CLEARADON® SERIES 3311 – VENT PIPE EQUIVALENT LENGTH DIAGRAM

For the Clearadon® Series 3311 aeration system to operate properly, the *equivalent* length of vent pipe must not exceed 95 feet. *Equivalent* pipe length calculations shown are based on this sample installation.

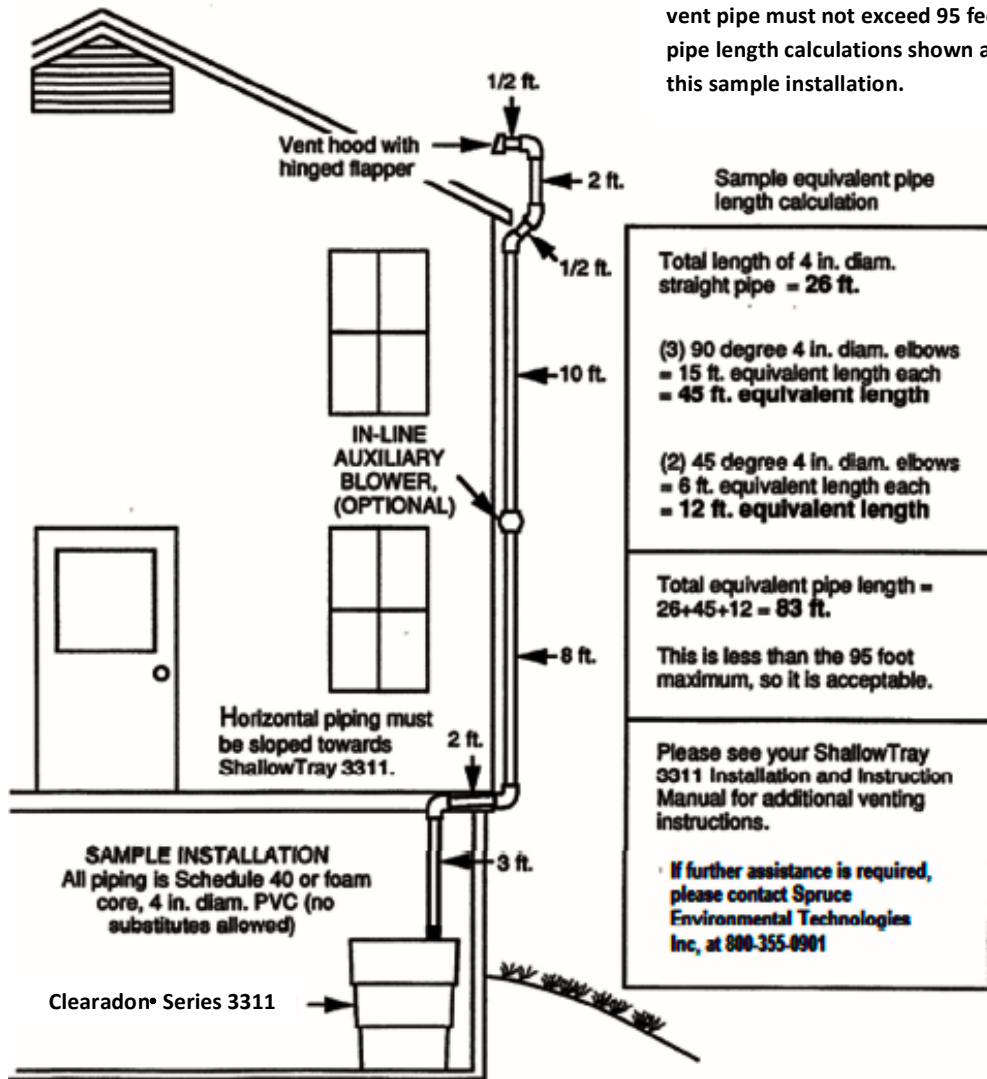

FIGURE 3

## START UP THE CLEARADON® SERIES 3311

### Step 1 – By-Pass System

Locate the black knob marked **push to by-pass**. Press the knob in.

### Step 2 – Turn off Pump

### Step 3 – Power Up

Check the main water line, then turn **on** the house well pump electrical power switch. Wait until the building has water pressure and check your plumbing connection for leaks. Fix any leaks before continuing with this section.

### Step 4 – Bring Clearadon® Series 3311 On-line

For Diverta-Flo bypasses, push **in** the black knob located on the brass By-pass assembly labeled **Push for Service**. If you have installed a 3 ball-valve bypass, set valves in the **Service** position. Check all plumbing joints for leaks and fix any that appear before continuing with this section.

### Step 5 – Turn Clearadon® Series 3311 On

Plug in the Clearadon® Series 3311. This action causes the blower to start and water to fill the holding tank. Allow the unit to run until the blower shuts off automatically. This will take approximately 3-4 minutes with the standard flow restrictors installed.

### Step 6 – Prime the Pump

### Step 7 – Start the Pump

Switch the pump pressure switch to **auto** (or plug the pump in again) and allow the pump to run. The pump will run until the pressure gauge reads approximately 60 psi.

Once the gauge has reached 60 psi, open three or more faucets and allow the system to run for approximately 15 minutes. Looks good? Turn off all the house faucets and check your work.

## INSTALLATION CHECK LIST

### Step 1 – Bypass

For Diverta-Flo bypass, by-pass the system by pushing in the black knob labeled **Push to Bypass**. If 3 ball-valve bypass, set valves to **Bypass** system.

### Step 2 – Uncouple the Vent Line and Inspect Float

Carefully remove the lid and blue spiraled aeration tray. Set them aside in a clean area. Inspect the two float switches located near the bottom of the tank and verify that they are floating freely. Reinstall the tray, making sure to align the marks (slots) on the tray with similar marks on the tank.

### Step 3 – Check Level Again

Remove the tank lid and check tank's position with a carpenter's level. Make any required adjustments to level the tank and keep it on a firm footing.

### Step 4 – Disinfect

Pour 1/2 cup of liquid chlorine into the center of the tray and another ¼ cup down the holes.

### Step 5 – Seal

Replace the lid and latch it securely. Secure the vent line and bring the system back on line. Listen to make sure there are no air leaks around the gasket cover and vent line.

### Step 6 – Verify Operation

Open a faucet and run the system for another 15 minutes. If everything is OK, place this manual and vendor literature in a safe and accessible place.

### Step 7 – One Month Later

Return to the site and test the system's performance. Take samples of treated and untreated water and submit them for contamination testing by a qualified testing facility. This visit is to check the systems performance and to be sure that there are no leaks or other installation problems. A representative sample of the treated water can be taken once at least 10 volumes of water have passed through the unit (approximately 120 gallons).

## OPERATING SEQUENCE FOR THE CLEARADON® SERIES 3311

Under normal operating conditions, the below control sequence is followed:

1. Pressure in the system pressure tank should be 60 psi for a typical 40-60 pressure switch setting.
2. Using approximately 5 gallons of water will drop system pressure to 40 psi.
3. The system pressure switch trips and starts the transfer pump.
4. Water is pumped from the holding tank to the pressure tank, and is then available for use by the home water system.
5. As water is transferred from the holding tank, the water level drops to the low-level setting. The low-level switch then trips a relay starting an air blower and opening the inlet water solenoid valves. Water flows from the well, through the existing home pressure tank, through the solenoid valves, and into the Clearadon® Series 3311.
6. When the water pressure in the system pressure tank rises to 60 psi, the system pressure switch shuts off the transfer pump.
7. When the water in the holding tank reaches the high level switch, the control relay shuts off the first solenoid valve and activates a timer that keeps the blower running for approximately 1 minute.
8. When the blower shuts off, treated water in the tray flows into the holding tank.
9. The second solenoid is installed as a backup. If the first solenoid fails to close, the water would continue to rise in the holding tank. The water level would reach the second float switch. This would cause the second solenoid valve to close.

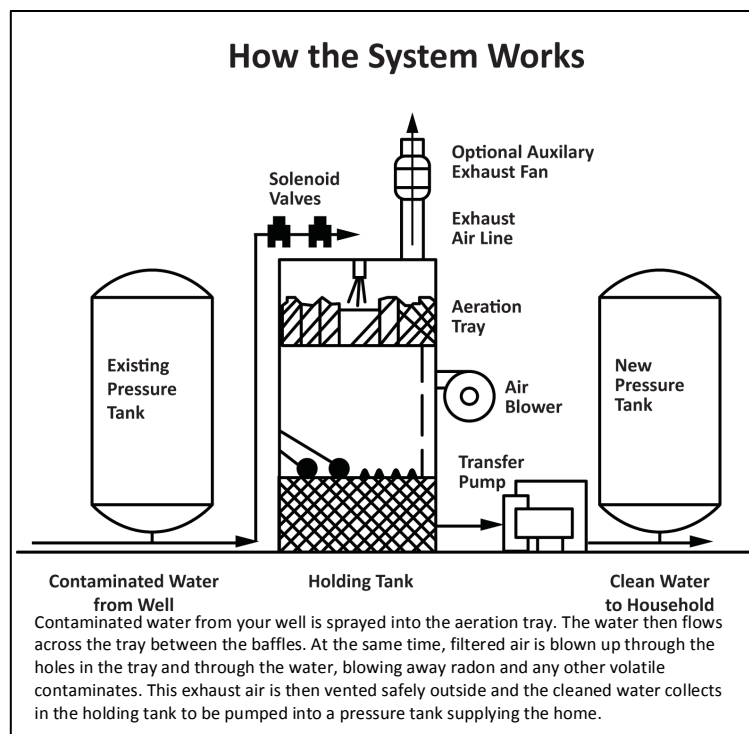

## MAINTENANCE

The Clearadon® Series 3311 has been carefully designed and constructed. In order to ensure years of trouble-free operation, the following maintenance procedures must be followed. There are no user- serviceable parts, so these maintenance procedures must be carried out by a licensed plumber or water treatment specialist.

### Water System Disinfection

It is possible that the Clearadon® Series 3311 can develop a colony of bacteria that live on iron in the water supply. These bacteria give off sulfur compounds as a by-product of their existence. Although the bacteria are understood to be harmless, they make the water unpalatable and odorous and should be removed.

If the water suddenly develops a smell of sulfur or rotten eggs, the possibility exists that iron bacteria have developed a colony either in the well or the Clearadon® Series 3311 unit -- or both. Enlist a licensed plumber or water treatment specialist to follow the standard well chlorinating procedure to eliminate the bacteria -- and the problem. This process will destroy the bacteria both in the well and the unit. Once the bacteria have been eliminated, care should be taken to completely flush out the Clearadon® Series 3311 system before placing it back on-line.

Keep a notebook wired to the Clearadon® Series 3311 unit for use as a maintenance log. Enter all maintenance and repairs performed, including the date and the cause of any malfunctions.

### Six Month Check

#### Step 1 – Test Water Quality

Take samples of treated and untreated water and submit them for contamination testing by a qualified testing facility.

#### Step 2 – Check the Following:

- Check all plumbing joints for leaks.
- Check the vent line and fan.
- Examine sediment filter (if installed) and clean if necessary.
- Check integrity of other custom water treatment equipment.
- Check spray nozzle, and holding tank for contaminants.
- Check solenoid and water level switches for correct operation.
- Check tank gasket and latches when reassembling system.
- Check cycling operation and water pressure.



### Step 3 – Disinfect

Pour 1/2 cup of liquid chlorine into tray and tank before resealing the tank cover and attaching the vent line. *Note the maintenance performed in the maintenance log.*

## **Annual Check**

### Step 1 – Same Again

Repeat the six month check.

### Step 2 – Replace Air Filter

Simply remove the filter and replace it with a new one.

### Step 3 – Switch Solenoid Coil Positions

Turn off the electrical power to the unit, remove the C-clips (E-rings) securing the solenoids, and simply switch their positions. Secure them with the C-clips. Turn on the electrical power, open three faucets, and observe the unit as it completes a cycle. *Note the performed tasks and observations in the maintenance log.*

## **Five Year Check**

Perform this check **every** five years. Pay special care to the installation site, the electrical connections, and the general integrity of the entire installation.

### Step 1 – Perform the Six Month and Annual Checks

### Step 2 – Replace the Solenoid Valves

Turn off electrical power to the unit; remove the C-clips securing the solenoid valves, and install new solenoid coils. Secure them with C-clips. Replace the valve too if there are any signs of wear. Turn on electrical power, open three faucets, and observe the unit as it completes a cycle.

### Step 3 – Replace All Hoses

Order a hose set from your Spruce representative, take the unit off-line, and install the new hoses. *Record your actions in the maintenance log.*

## TROUBLESHOOTING GUIDE

The following guide lists the most common problems encountered with a Clearadon® Series 3311 installation. These instructions are for use by a licensed plumber or water treatment specialist. If you require assistance in locating a suitable professional, please call your local Clearadon® Series 3311 representative.

### Poor Contamination Removal

#### Step 1 – System Level?

Remove the aeration cover and use a builder's level to check the tank level. Use shims if required to securely level the tank in all directions.

#### Step 2 – Check Vent Length

The vent must be 4 inch PVC and must not exceed 95 feet in length; including the equivalent length of fittings and elbows. The fittings must be cemented. See **Step 11** in the Installation procedure for the correct venting instructions.

#### Step 3 – Check Vent Cap

The vent cap should have a flapper (or screen) at the end of a 90 degree elbow at the vent end. If it has a flapper, check to be sure it moves freely and that it closes when the Clearadon® Series 3311 is off. If it has a screen, be sure that the screen is clear of debris.

#### Step 4 – Check Vent Line

Make sure that the vent line is not obstructed by ice, debris, birds, etc. Eliminate any sags in the line and check that any horizontal pipe installation slopes back towards the Clearadon® Series 3311 unit. See **Step 11** in the Installation procedure.

#### Step 5 – Check Blower Air Filter

If the air filter is contaminated by lint, dirt, etc., simply remove the filter and clean it in soapy water. The filter must be replaced every year.

#### Step 6 – Check Auxiliary Fan

If the fan refuses to work, first check the house circuit breaker panel then examine the fan for electrical integrity.

### Step 7 – Check Outlet Weir

Check that the 1-1/2 inch-tall PVC weir plate in the spiral aeration tray is firmly seated in its slot.

### Step 8 – Check Aeration Tray

Remove the tray and check it for contamination. Wash and rinse it thoroughly in soapy water making sure that all the holes are unobstructed.

### Step 9 – Check By-Pass Valve

A damaged by-pass valve plunger will allow untreated water to by-pass the treatment unit. The plunger should be inspected and lubricated yearly.

### Step 10 – Check Test Results

If your test results are inconsistent and considered inaccurate, make sure that the unit has run through at least ten on-off cycles (120 gallons) before beginning testing. For accurate test results, untreated and treated samples should be taken at the same time and tested together at the same testing facility.

## **Problem: Air in Water**

### Step 1 – Check Well Flow Rate

Turn to **Step 1** of the Installation procedure and determine the flow rate.

### Step 2 – Check Water Feed

- **Solution A.** Remove and clean the filter (if installed) in the piping between the AIRaider 3311 and water supply.
- **Solution B.** You must determine the flow through the feed plumbing that includes the spray nozzle. Begin by by-passing the system by removing the feed hose from the cover. Remove the plastic bulkhead fitting and spray nozzle from the cover, then reassemble from cover. Place the hose and nozzle in a bucket. Push the by-pass valve to service and turn on a house faucet until the solenoids open and water flows into the bucket. Measure. In gallons per minute, the flow into the bucket. If the flow rate is less than is indicated on tile inlet flow restrictor, remove the spray nozzle and repeat the flow check. If the flow is still insufficient, independently check the flow through the by- pass valve and each solenoid. Check one solenoid at a time.

**Caution:** Do not change or remove the outlet flow restrictor without exchanging the inlet flow restrictor for one that has a slightly higher flow. For example, if the outlet is 9 gpm the inlet should be 10 gpm. Increasing tile inlet flow rate above 7 gpm will decrease the Clearadon® Series 3311 efficiency in removing contaminants.

**Problem: Pump Will Not Shut Off**

Step 1 – Check Tile Pressure

Check tile pressure line from the repressurization pump to the pressure switch. This line can get fouled up and prevent the switch from operating correctly. Remove tile line and clean it out. Also check the fittings where the line connects to the pump and to tile pressure switch. Be sure these fittings are also cleaned out.

**Problem: Low Water Flow**

Step 1 – Determine Well Flow Rate

See page 5 of the Installation procedure. Note that system has built-in flow restrictors to prevent air from entering tile system and to achieve maximum efficiency. The inlet flow restrictor allows 7 gpm into the treatment tray. The outlet flow restrictor allows 6 gpm into the house. If the well currently feeds the house at 10 gpm, a 6 gpm outlet flow restrictor may not provide adequate water flow. Higher flow rates can be achieved by increasing the size of flow restrictors, but a decrease in performance will be observed.

**Caution:** Always use an inlet flow restrictor of slightly higher flow rate than the outlet flow restrictor. Failure to do this will allow air to enter the house plumbing system.

Step 2 – Check for Obstruction in Suction Side of Pump

Remove check valve and inspect for fouling or sticking. Clean or replace as necessary. Inspect all plumbing between the aeration tank suction elbow and pump suction elbow for obstruction or kinks.

Step 3 – Check for Obstruction on Discharge Side of Pump

Inspect all plumbing lines and joints between pump discharge nipple and bypass valve for obstructions.

**Problem: Pump Malfunction after a Power Failure**

If tile system will not start after a power outage or system malfunction, perform the following steps.

### Step 1 – Check Pump

The system is equipped with a low pressure cutoff switch. If water supply to the Clearadon® Series 3311 is inadequate the pump will automatically shut off to prevent it from burning out.

Push in the **Push to By-pass** knob. This allows water to flow directly from your pressure tank to the house, bypassing the Clearadon® Series 3311. Unplug the Clearadon® Series 3311. Turn to page 9 in this manual, and restart the system.

### **Problem: Pump Starts but No Water Flow**

#### Step 1 – Examine Check Valve

Inspect check valve for fouling or sticking. Get the system up to full pressure (approximately 60 psi), push in the by-pass valve, and observe the pressure gauge. If pressure slowly decreases inspect valve. If the valve is fine, look for a slow leak in the aeration system piping. Also check for a slow leak in the house plumbing; a leaking toilet, for example.

### **Problem: Pump Quits, House Requires Water**

#### Step 1 – Check Flow Rate

If there is an inadequate flow rate, correct as you would for air in water.

#### Step 2 – Check Plumbing

Check for leaks in the piping on the suction side of the pump. Check air discharge in the pressure tank; refer to the pressure tank owner's manual for instructions.

#### Step 3 – Check Pressure Switch

Check the setting, and refer to the pressure tank owner's manual.

#### Step 4 – Check Circuit Breaker

Check the house fuse or circuit breaker that protects the Clearadon® Series 3311 unit. Reset or replace as needed.

## ELECTRICAL PROBLEMS

### **Problem: System Will Not Start**

#### Step 1 – Check Pump

See *Problem: Pump Malfunction* above, perform the steps, then return here.

#### Step 2 – Check Aeration Tank Fuse

Check the fuse in the control panel on the aeration tank. Replace if necessary,

#### Step 3 – Power Failure or Circuit Breaker Reset

Restart the system by lifting the pump pressure switch (on side of pump) to the Start position. Release once the pump is running.

### **Problem: Solenoids Do Not Operate**

Water will not flow to the house if the solenoids malfunction. Refer to the solenoid Installation manual. Inspect float switches to determine that they are free from obstruction. Lift, then drop each switch separately, and listen for solenoid operation. Note that the float switches must be approximately 3 inches below level before they will reset.

### **Problem: Blower Malfunction**

If water is flowing to the Clearadon® Series 3311 but the blower will not run, perform the following steps:

#### Step 1 – Check Relay Contacts

Ensure that the relay contacts are dry, free from corrosion, and fully seated in their sockets.

### **Problem: Blower Runs Continuously**

If the blower refuses to shut off after the water flow into the Clearadon® Series 3311 system stops, perform the following steps:

#### Step 1 – Check Float Switch

Ensure that the float switch is not stuck in the down position.

Step 2 – Check Relay

Ensure that the relay contacts are dry, free from corrosion, and fully seated in their sockets.

Step 3 – Check Timer

Check the timer for proper time setting. Note that the timing marks are for reference only, and may not delay as shown.

## PACKING LIST

- Clearadon® Series 3311 Assembly
- Solenoid Valves(2)
- Flow Restrictors(2)
- Operation
- Manual

## INSTALLATION OVERVIEW

Installation of the Clearadon® Series 3311 basically consists of seven steps. They are:

1. Check the well pump flow rate. This step must be performed prior to installation.
2. Prepare the installation site.
3. Move the unit to the site, unpack, and ready all pieces.
4. Connect and plumb the inlet and outlet water pipes.
5. Connect electrical power.
6. Install the unit's air vent line.
7. Test.

See Figure 1 for an overview of the completed system.