

# Low Yield Well Storage Systems



**AIR & WATER QUALITY INC.**

160 US Route 1 • Freeport, ME 04032  
388 Bangor Road • Ellsworth, Me 04605  
Tel # (800)698-9655 • awqinc.com

## Introduction

Wells drilled directly into bedrock tend to be low yield wells. Peak demands can require more water than the well can provide. This article describes possible options and issues to consider when choosing a solution to a low yield well. You have three options if you don't have enough water. The options are as follows:

- Drill the well deeper to provide more storage and perhaps hit a fissure that produces more water.
- Hydrofracture the well.
- Provide auxiliary storage.

## Drilling Deeper

If you decide to drill the well deeper, you will need to consider the following:

- Introduction of poorer quality water to your system
- Increasing the size of your systems pump
- Salt water intrusion along coastal areas
- Expense (often as much as a new well- \$4000 or more)
- NO GUARANTEE OF SUCCESS.

## Hydrofracturing

Hydrofracturing is the process of placing hydraulic pressure on the bedrock surrounding the well for the purpose of enhancing the yield of water. A device called a packer is lowered into the hole and inflated below the well casing to seal the top of the well. Water is then pumped at 25-60 gpm through the packer and into the well. The pressure created blows water into the fractures cleaning out obstructions.

If you decide to hydrofracture the well, you will need to consider the following:

- Introduction of poorer quality water to your system
- Expense ( \$2,000 or more)
- NO GUARANTEE OF SUCCESS.

## Storage

Most wells yield water at a rate that would be adequate if the demand could be spread evenly throughout the day. This can best be done by providing storage for periods of high demands.

In a storage system, water is pumped to an atmospheric tank and then re-pumped by a second pump to the house. The storage can be provided in the form of an

above or below ground storage system. The simplest system consists of a polyethylene storage tank above ground.

The size of the storage tank will depend on the volume of water required during peak demands. Generally, a design of a system assumes that the total amount of water used in the typical residence occurs over a 4 hr period (1/2 in the morning and 1/2 later in the day). The storage is sized to only handle a single two hour peak because the system will have time to refill the tank before the next peak.

*Example-*

A family of 4 uses 60 gallons per day per person. This total use for the day is 240 gallons. If we assume half of this is in the morning and half of this is later in the day, the storage required will be 120 gallons.

When deciding whether to use auxiliary storage or not consider the following:

- This system can guarantee an adequate water supply.
- The storage tank needs to be made from NSF approved material.
- Whether or not you should provide disinfection of the storage tank and water.
- The air that allows the tank to breath as it fills and empties needs to be filtered.
- Provisions must be made to protect the well pump and repressurization pump from damage if they run out of water.

## What we need to know to design a storage system?

- Piping sizes
- numbers of guests , lawn watering or irrigation, etc ...)
- Customer expectations
- type and size
- Size of access doorways
- Space available for installation
- Well recovery rate
- Any special equipment already installed(well pump protection, low pressure cut out switch, etc ...)
- Typical use of well (only on weekends, large

AIR & WATER QUALITY INC.  
160 US Route 1, Freeport, ME 04032  
388 Bangor Road, Ellsworth, ME 04605  
1(800)-698-9655 awqinc.com

# Low Yield Well Storage Systems



**AIR & WATER QUALITY INC.**

160 US Route 1 • Freeport, ME 04032  
388 Bangor Road • Ellsworth, Me 04605  
Tel # (800)698-9655 • awqinc.com

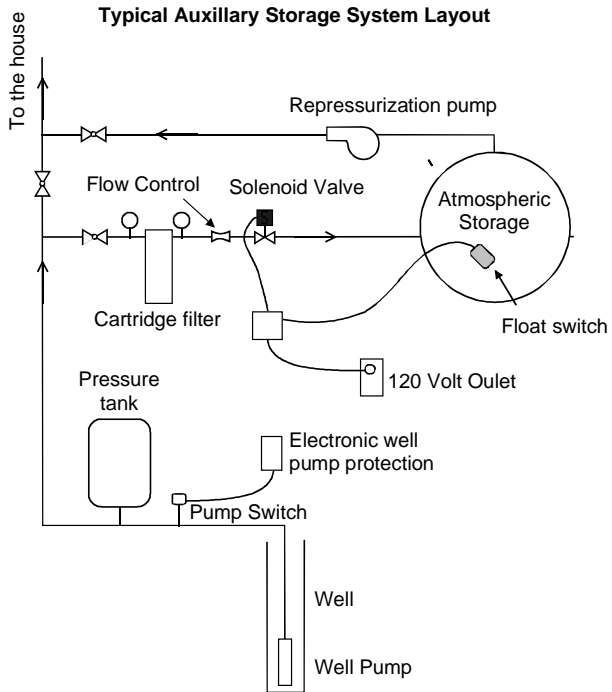

AIR & WATER QUALITY INC.  
160 US Route 1, Freeport, ME 04032  
388 Bangor Road, Ellsworth, ME 04605  
1(800)-698-9655 awqinc.com